

A Power-Saving Multi-radio Multi-channel MAC Protocol for Wireless Local Area Networks

Jianfeng Wang, Yuguang Fang, Dapeng Wu
Department of Electrical & Computer Engineering
University of Florida, Gainesville, Florida 32611-6130
E-mail: jfwang@ufl.edu, fang@ece.ufl.edu, wu@ece.ufl.edu

Abstract—Opportunistic spectrum access and adaptive power management are effective techniques to improve throughput, delay performance, and energy efficiency for wireless networks. In this paper, we consider the joint design of opportunistic spectrum access and adaptive power management under the setting of multi-radio nodes and multi-channel wireless local area networks (WLANs) under the distributed coordination function (DCF) mode. This design problem is particularly challenging due to the conflicting nature of the multi-radio capability of a node, i.e., multiple radios improve throughput and delay performance at the cost of increased energy consumption. To address this problem, we propose a power-saving multi-channel MAC protocol (PSM-MMAC), which is capable of reducing the collision probability and the waiting time in the ‘awake’ state of a node, resulting in improved throughput, delay performance, and energy efficiency. The key ideas of PSM-MMAC are the following: we first estimate the number of active links; given this estimation as well as queue lengths and channel conditions, we appropriately select channels, radios, and power states (i.e., awake or doze state); then we optimize the medium access probability in p -persistent CSMA used in the data exchange. Another contribution of this paper is an analytical model that characterizes the throughput performance. Simulation results validate the accuracy of our analytical model and show that our proposed protocol is able to significantly improve both throughput and energy efficiency.

I. INTRODUCTION

With the tremendous popularity of wireless applications and the increasing usage of battery-powered wireless communication devices, people demand higher throughput and longer “online” time, which boost the necessity to improve both network capacity and energy efficiency.

It is known that opportunistic spectrum access has the potential to significantly improve network capacity, and adaptive power management is effective in saving battery-power. So, in order to improve both network capacity and energy efficiency, joint design of opportunistic spectrum access and power management seems very promising. In this paper, we investigate this joint design issue under the setting of multi-radio¹ nodes and multi-channel WLANs under the distributed coordination function (DCF) mode [1], which has not been studied, to the best of our knowledge.

This work was supported in part by the U.S. Office of Naval Research under Young Investigator Award N000140210464 and by the National Science Foundation under Faculty Early Career Development Award ANI-0093241 and under grant DBI-0529012.

¹One radio corresponds to one wireless Network Interface Card (NIC).

Three observations motivate this investigation. First, multiple non-overlapping channels are available for the IEEE 802.11 standard. For example, in USA, 11 channels are available for IEEE 802.11b and 12 channels are available for IEEE 802.11a; in Europe, 13 channels are available for IEEE 802.11b and 19 channels are available for IEEE 802.11a. Second, as the prices of RF transceivers (radios) have fallen dramatically, it is feasible for us to consider using two or more radios in the same node, each of which can independently transmit/receive packets in a separate channel. Third, the delay in switching channels has been reduced to tens of microseconds [3] [13] and the delay in switching power-states (e.g., switching between awake state and doze state) is hundreds of microseconds or less; hence, dynamically selecting a good channel can help improve throughput and delay performance, and changing power-states can help save energy on the time-scale of a packet level.

The aforementioned joint design problem is especially challenging due to the conflicting nature of the multi-radio capability of a node, i.e., multiple radios improve throughput and delay performance at the cost of increased energy consumption. For example, in the low load case, if each radio of a node is in the awake state and participates in channel contention (in different channel), the delay could be significantly reduced; but the energy consumption will be increased since multiple radios of a node are in the awake state. On the other hand, in the high load case, the increase of the number of radios potentially increases the collision probability; so, if each radio of a node is in the awake state and participates in channel contention, both throughput and energy efficiency can be degraded. To address this problem, we propose a power-saving multi-channel MAC protocol (PSM-MMAC), which is capable of reducing the collision probability and the waiting time in the ‘awake’ state of a node, resulting in improved throughput, delay performance, and energy efficiency.

The key ideas of PSM-MMAC are the following: we first estimate the number of active links²; given this estimation as well as queue lengths and channel conditions, we appropriately select channels, radios, and power states (i.e., awake or doze state); then we optimize the medium access probability in p -persistent CSMA used in the data

²An active link (directed) is defined as a node-pair with pending packets for transmission from sender to receiver.

exchange. To save the overhead, in our PSM-MMAC, the channel conditions are measured in a passive (eavesdropping) manner and in a channel-hopping manner. The proposed PSM-MMAC performs on the time-scale of a beacon-interval [1] so that it can be more responsive to traffic dynamics and channel dynamics; and the PSM-MMAC is able to achieve good performance under various traffic and channel conditions. One nice feature of PSM-MMAC is that it can cope with a heterogeneous multi-radio system, in which each node may have different number of radios. The implementation of PSM-MMAC requires minimal modification of 802.11 hardware.

Another contribution of this paper is an analytical model that characterizes the throughput performance. The analytical model is general in the sense that it is applicable to any MAC protocol that consists of a channel-contention phase and a data-exchange phase, where the channel-contention phase precedes the data-exchange phase, and indicates the traffic load or reserves the channel in the data-exchange phase. Simulation results validate the accuracy of our analytical model and show that our proposed PSM-MMAC protocol is able to significantly improve both throughput and energy efficiency.

The rest of the paper is organized as follows. In Section II, we introduce the preliminaries and discuss the major design issues. Then we discuss the related works in Section III and present our PSM-MMAC protocol in Section IV, respectively. In Section V, we provide an analytical model to evaluate the throughput performance. In Section VI, we present results and further discussions. Finally, we conclude the paper in Section VII.

II. PRELIMINARIES AND DESIGN ISSUES

A. Channels, Radios and Power-States

We assume a wireless LAN provides multiple channels for free use. To determine which group of channels are available for a specific wireless LAN is another interesting issue, which is out of the scope of this paper. Depending on physical capability of a node, one node may have one or several radios. One radio can be dynamically switched to one channel for either transmit or receive or sense. A radio can be in the awake state or the doze state. In the doze state, a radio consumes no power. In the awake state, a radio may be in one of three different modes, namely, transmit, receive, and idle modes, and consumes significantly more power than the doze state. In the doze state, a radio cannot transmit or receive or sense, and consumes very little power. For instance, a Cisco AIR-PCM 350 802.11b radio consumes 1.875 W, 1.3 W and 1.08 W in the transmit, receive and idle modes, respectively, in the awake state and consumes only 0.045 W in the doze state.

Since even the idle mode consumes significant power, the basic DCF access procedure in IEEE 802.11, which requires each node to continually listen to the channel, is not energy-efficient.

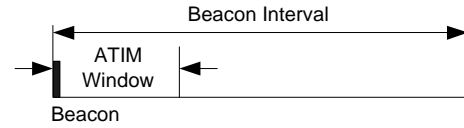

Fig. 1. Timing Structure of IEEE 802.11 PSM in the DCF.

B. Power Management in IEEE 802.11 WLANs

To save power, IEEE 802.11 provides a power-saving mechanism (PSM) called IEEE 802.11 IBSS PSM [1]³ for DCF-based WLANs. The basic idea of IEEE 802.11 IBSS PSM is to reduce the idle time as much as possible. As shown in Fig. 1, time in IEEE 802.11 IBSS PSM is divided into identical beacon intervals. At the start of each beacon interval, all nodes stay awake for an ATIM (Ad-hoc Traffic Indication Message) window, the size of which is static in IEEE 802.11 IBSS PSM. When a node has packets destined for another node, it may transmit an ATIM to the intended receiver during the ATIM window. Upon receiving ATIM, the intended receiver shall reply an ATIM-ACK. The (re)transmission of ATIM follows the normal DCF access procedure. Following the end of the current ATIM window, any node neither having sent an ATIM nor having received an ATIM containing its own address during the ATIM window shall enter the doze state. Any node which has sent an ATIM or received an ATIM containing its own address during the ATIM window shall remain in the awake state until the end of the next ATIM window. Those nodes in the awake state transmit/receive DATA by the conventional DCF access procedure.

C. Design Issues

In this section, we discuss the major design issues on power-saving multi-radio MAC protocol. In comparison with single-radio single channel wireless LANs, multi-radio multi-channel wireless LANs give much larger design space. For example, like the idea introduced by Nasipuri et al. [6], each node may listen to all channels concurrently and opportunistically select one or several idle channels to transmit packets if each node has enough radios to sense all channels; or similar to the idea introduced by Wu et al. [9], we may use one channel for control messages and other channels for data; or following the IEEE 802.11 PSM timing structure illustrated in Fig. 1, all nodes stay awake on a default channel during ATIM window for exchanging control messages and switch to negotiated channel(s) for data after ATIM window [14].

In our design, we advocate IEEE 802.11 PSM timing structure for power-saving multi-radio MAC because of its potential to save energy and its flexibility to support heterogeneous multi-radio system. Next, we discuss major design issues for a power-saving multi-radio MAC protocol under the IEEE 802.11 PSM timing structure.

³Since only one radio is considered in each node in IEEE 802.11 PSM, the power-state of a node means the power-state of the radio in that node when we discuss IEEE 802.11 PSM.

1) *Channel negotiation during ATIM window*: During an ATIM window, all nodes stay in a common channel and follow DCF process to exchange ATIM. A winning node-pair (including a sender and a receiver) shall decide which radio and which channel to be used to transmit/receive data following the ATIM window. There are a few of issues need to be considered in channel negotiation.

- *Heterogeneous radios*: Different node may have different number of radios. A node with only one radio can only switch to one channel for data exchange. However, a node with multiple radios can wake several radios simultaneously for transmitting and/or receiving data, each of which runs in a separate channel. This is beneficial especially when the incoming traffic to the node and/or the outgoing traffic from the node is high.
- *Channel quality*: For a given node-pair, the achievable data rate(bits/sec) and power efficiency (joules/bit) in different channel band may be quite different.
- *Traffic load*: To balance traffic in different channel bands can reduce contention overhead (considering DCF based channel access is used for data exchange), improve fairness and increase channel utilization.

2) *Updating ATIM window size*: The ATIM window size specified in 802.11 is static. However, as demonstrated by simulation in [21], the ATIM window size critically affects throughput and energy consumption. If the ATIM window is large, it would leave less time for actual data transmission, potentially degrading throughput, and it would cause a lot of energy wasted for being idle in ATIM window. If the window size is too small, it could also degrade throughput because it may not provide enough time for ATIM exchanges. Remember all nodes need to exchange ATIM before intending to transmit data. To save energy while not degrading throughput, ATIM window size must be adaptive to traffics.

3) *Medium access control to exchange ATIM and exchange data*: In IEEE 802.11 IBSS PSM, CSMA/CA based medium access control is required for ATIM exchange and data exchange. As we know, the performance of CSMA/CA based MAC, in terms of throughput and delay, is sensitive to medium-access parameters (contention-window size in backoff algorithm and medium-access probability p in p -persistent algorithm). Although, the de facto binary exponential backoff algorithm is simple, it is not efficient and not fair(it always favor those who just win the channel) [34]. How to optimize those medium-access parameters is an old question but still deserves further investigation.

III. RELATED WORK

There are many studies undertaken on multi-radio multi-channel system [4]– [20] and power-saving mechanisms [21]– [33]. So far, there is no existing work considering both opportunistic spectrum utilization and power-saving into multi-channel MAC design. Next, we will review ad-hoc multi-channel MAC protocols and the enhancement of IEEE 802.11 IBSS PSM, which are most related to our work.

A. Ad-hoc Multi-channel MAC protocols

According to whether there is control channel and how many radios can be used for data exchange concurrently in each node, we can classify existing schemes into four categories.

In the first category of multi-channel schemes [6]–[8], each node can listen to all channels concurrently and opportunistically select one channel to transmit packets. These schemes are distinguished by channel selection algorithms which consider channel availability and/or channel condition. These protocols require C transceivers for each node, where C is the total number of channels.

In the second category of multi-channel schemes [9]–[11], one dedicated channel is maintained for control messages and other channels are allocated for data. Each node has two radios, one is for control channel and another is switched to one selected channel. These schemes are distinguished in data-channel selection algorithms according to channel availability, traffic load and/or channel condition. One consideration in this category of solutions is that, if each channel has the same bandwidth, one channel dedicated for control messages can be costly when the number of channels is small, and one channel dedicated for control messages may not be enough when the number of channels is large.

In the third category of multi-channel schemes [12]–[15], no dedicated control channel is needed and only one radio is available in each node. Tzamaloukas et al [12] propose a receiver-initiated channel-hopping scheme. Nodes carry out a receiver-initiated collision-avoidance handshake to determine which sender-receiver pair should remain in the present hop in order to exchange data, while all other nodes that are not engaged in data exchange continue hopping on the common hopping sequence so that they can exchange control messages on the same channel at the same time. Bahl et al. [13] propose another channel hopping solution for multi-channel ad hoc networks. Each node locally exchanges and updates its own channel hopping schedule such that nodes desiring to communicate can keep on the same channel for certain time fraction, while disjoint communications mostly do not overlap, and hence do not interfere with each other. So et al. [14] propose a MAC timing structure similar to IEEE 802.11 PSM to negotiate channel and handle multi-channel hidden terminal problem in multi-hop ad hoc networks. Kanodia et al. [15] propose a channel skipping scheme such that if the signal to noise ratio on the current channel is not favorable, mobile nodes can opportunistically skip to better quality frequency channels which can enable data transmission at a higher rate.

Similar to the third category of multi-channel schemes, the fourth category [17]–[19] also assume there is no dedicated control channel but there are multiple radios available in each node for concurrent data exchange. Adya et al. [17] propose a link-layer solution called MUP for striping data over multiple radios. The goal of MUP is to optimize local spectrum usage via intelligent channel selection in a multi-hop wireless network. The proposal does not use channel switching, and for full utilization of available channels, a radio

is necessary for each channel. Kyasanur et al. [18] consider the scenario in general multi-hop networks when multiple radios are available, but the number of available radios is less than the number of available channels. A hybrid radio assignment strategy is proposed so that some radios can stay in some channels while other radios can dynamically switch to one of the available channels. Raniwala et al. [19] propose routing and radio assignment algorithms for mesh networks. It assumes traffic loads between all nodes are known, and using the load information, radio assignment and route computation is intelligently carried out.

Our scheme falls into the fourth category but could be more general in the sense that each node may have different number of radios. In addition, it has carefully taken both spectrum utilization and power-saving into our design. All the aforementioned multi-channel MAC protocols basically intend to improve channel utilization, while only one multi-channel MAC protocol, which incorporates transmit power control [20], aims to improve channel utilization by increasing the spatial reuse.

B. Enhancement of IEEE 802.11 IBSS PSM

In [21], it is shown that a static ATIM window in IEEE 802.11 IBSS PSM does not work well for all traffic loads. Jung et al. [27] attempt to dynamically adjust the ATIM window size in single-hop networks (i.e., WLANs) based on indications such as the listening time at the end of the ATIM, the number of packets pending for a node, and the number of packets that could not be advertised in the previous beacon interval.

In TIPS [29], the ATIM window is divided into two slots. If a beacon packet is received during the first slot, it indicates that nodes should stay awake to receive ATIMs later in the ATIM window. If the first beacon packet is not received until the second slot, then the node can return to sleep since no more advertisements will follow.

Miller et. al [31] consider three techniques to improve the 802.11 PSM protocol. The first technique, Carrier Sense ATIM (CS-ATIM) adds a short carrier sensing period T_{cs} at the beginning of each beacon interval. Rather than every node waking up for ATIM window at the beginning of every beacon interval, the nodes will only wake up for T_{cs} at the beginning of every interval when there are no packets to be advertised. When there are packets to be advertised, the nodes will wake up for an entire ATIM window after the carrier sensing period. The second technique, D-ATIM adjusts the current ATIM window based on the traffic in the current beacon interval. The final technique, Per-Link Beacon Intervals, allows sender and receiver pairs to schedule their wake-up times independent from all the other nodes in the network based on past packet arrival times.

Similar to [31], we add a short carrier sensing period at the beginning of a beacon interval to detect whether there are data packets pending for exchange; if no, all nodes will directly enter into doze state until the next beacon interval. The difference in our scheme is that rather than just determining whether there is pending traffic, we develop an efficient

scheme to estimate the number of active links. With the estimated number of active links, the ATIM window size and the medium-access parameter (e.g., the medium access probability of the p -persistent algorithm or the contention window size of the backoff algorithm) can be appropriately adjusted.

Moreover, all the existing schemes basically target single-channel wireless system and have not investigated multi-radio multi-channel networks which we will consider in this paper.

IV. PROPOSED POWER-SAVING MULTI-CHANNEL MAC PROTOCOL (PSM-MMAC)

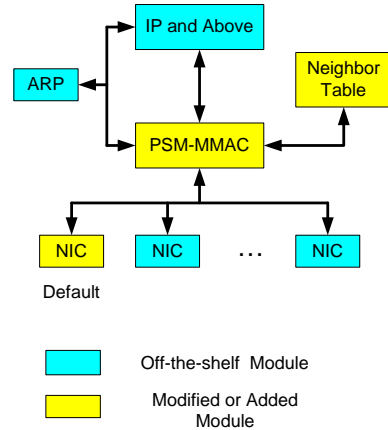

Fig. 2. Proposed Firmware Architecture

A. Firmware Architecture

The proposed firmware architecture is shown in Fig. 2. The design rationale is to optimize the spectrum efficiency and energy efficiency with minimal change to the standard-compliant IEEE 802.11 hardware. It also aims to ensure the inter-operability between heterogeneous nodes in which different nodes may have different number of radios.

We implement PSM-MMAC in the link layer, which is over multiple independent NICs and under an unified IP-layer. Under the coordination of PSM-MMAC, multiple interfaces (one in a separate channel) can be opportunistically utilized to distribute network traffic without any modification to applications or to the upper layers of the network protocol stack.

Each node maintains one table for each neighbor to describe the neighbor's physical capability(e.g., the number of NICs), link quality (per-channel link quality is maintained) and queue status (per-neighbor queue is maintained in the link-layer). Based on these information and the expected traffic load in each channel, channel and NIC will be appropriately selected by PSM-MMAC for data exchange.

We assume each node has at least one default NIC which can coordinate with PSM-MMAC to perform traffic indication and channel negotiation. A node may also have several extra NICs, which could be the off-the-shelf 802.11 wireless NICs. To hide the complexity of multiple network interfaces from

applications and from the upper layers of the protocol stack, PSM-MMAC exposes a single MAC address, which is owned by the default NIC, in place of the multiple physical MAC addresses used by the wireless Network Interface Cards (NICs). From the application perspective, the system operates as if there is only a single wireless network interface (the default NIC).

The proposed MAC timing structure is shown in Fig. 3. Time is divided into identical beacon intervals. At the beginning of each beacon-interval, the default NIC switches to the default channel and remains awake for an ATIM window. During the ATIM window, the default NIC performs traffic indication (based on per-neighbor queue status), and negotiate channel and NICs (including extra NICs and the default NIC) to exchange data. Right after channel negotiation, the extra NICs can turn to be awake in the selected channel and exchange data (we assume the extra NICs normally are put in doze or off state and turned to be awake on-demand, thus reducing power consumption). We propose a channel and NIC selection algorithm so that the number of NICs available in each node and the channel quality (for a given node-pair) in each channel can be taken into consideration, and traffic can be balanced in each channel. After ATIM window, the default NIC will also serve to exchange data in the default channel if necessary. All the waken NICs may turn into the doze state after completing data exchange if the duration from the completion time to the next beacon-interval is longer than certain threshold.

As described in section II-C, there are several critical issues need to address in power-saving multi-radio multi-channel MAC protocol. Next, we will first detail the proposed MAC timing structure.

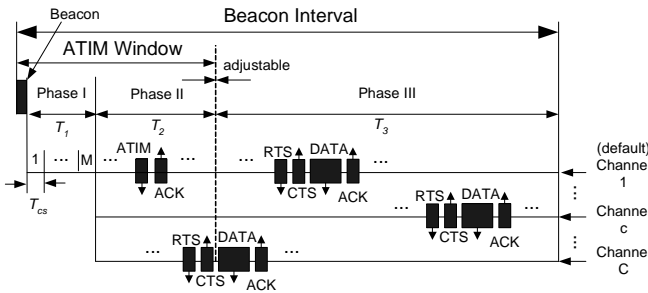

Fig. 3. Proposed MAC Timing Structure

B. Overview of PSM-MMAC Protocol

As shown in Fig. 3, time is divided into identical beacon intervals. There are three phases in each beacon-interval after synchronization beacon. Phase I serves as the estimation of the number of active links. Phase II in the default channel serves as traffic indication and channel negotiation; Phase II in channels other than the default channel can be used to exchange data. Phase III serves as data exchange.

Phase I consists of M identical mini-slots. All nodes stay awake in the default channel during phase I. Each sending

node of an active link randomly selects one mini-slot to transmit busy signal (if a node has multiple output links, it randomly selects multiple mini-slots to transmit busy signal). An algorithm is developed in our paper to estimate the number of active links given the number of busy mini-slots observed in phase I. If no active link is observed at the end of phase I, all nodes enter into doze state directly and remain doze state until next beacon interval. Otherwise, all nodes go to phase II to exchange ATIM, for traffic indication and channel negotiation (still in the default channel).

ATIM exchange follows p -persistent based (or backoff based) CSMA protocol. The number of active nodes estimated at the end of Phase I is used to optimize the Phase II duration and medium-access probability (or contention-window size). Once ATIM exchange between a node-pair succeeds, the winning node-pair will select a channel for data exchange according to channel quality and expected traffic load in each channel.

During Phase II, we enforce that each node must keep awake in the default channel to listen to traffic indication. But we also allow those node-pairs who have exchanged ATIMs to exchange data in other channels if they have extra radios. After Phase II, those nodes having exchanged ATIMs continue to be awake until they have completed data exchange. Other nodes (which neither transmitted nor received ATIM go to doze until the next beacon interval.

For data exchange in Phase II (in non-default channel) and Phase III, p -persistent based (or backoff based) CSMA is also used for RTS/CTS handshake. Since the number of intended transmission nodes in each channel could be known to each node after channel negotiation, each active node can also optimize the medium-access probability (or contention window size) to resolve RTS/CTS collision. To take advantage of channel dynamics on the time scale of packet level, link adaptation is incorporated in our scheme. RTS/CTS not only serves as collision resolution, but also for channel probing. A node-pair can choose appropriate transmission rate or transmission power to exchange data after successful RTS/CTS.

C. Estimation of the number of active links

In order to estimate the number of active links, we divide Phase I into M mini-slots. Each mini-slot lasts T_{cs} , which is set to be long enough for judging whether channel is busy or not. If a link has traffic in current beacon interval, the sender may randomly select one traffic-indication mini-slot and transmit busy signal. By counting busy mini-slots, all nodes can estimate how many links intending to advertise traffic at the end of Phase I.

Clearly, the number of intended advertising links is zero if no busy mini-slot is observed at the end of Phase I. However, the number of intended advertising links could be larger than the number of observed busy-slots if it is non-zero since two intended advertising links may select the same mini-slot.

Denote the number of intended advertising links as n . Given M and n , the probability that the number of observed busy

TABLE I
NOTATION

Parameter	Description
C	The number of channels in the system
K_i	The number of radios (NICs) at node i
$\overline{SINR}_{i,j,c}$	The weighted average SINR from node i to node j at channel c
$R(\overline{SINR})$	Achievable data rate as a function of SINR.
T_c^a	The available time-allocation at channel c .
L	The maximal packet length allowed in the MAC player to transmit as a burst.
T_{over}	The PHY and MAC layer overhead to transmit a data packet.
$Q_i^j.\text{length}$	The queue length in node i for neighbor j .

slots equals m , can be represented as

$$\Pr(M, n, m) = \frac{\binom{M}{m} \binom{n-1}{m-1}}{\binom{n+M-1}{M-1}}. \quad (1)$$

Assume n does not change fast from one beacon interval to another. Under this assumption, the statistical distribution of the number of busy-slots observed in current and past beacon-intervals can be used to estimate n accurately. Denote p_i^k as the PMF (probability mass function) that the number of busy-slots observed in and before k^{th} beacon-interval equals i . Denote m^k as the number of busy slots observed in k^{th} beacon-interval. Now we can estimate the number of intended advertising nodes in k^{th} beacon-interval as

$$\hat{n}^k = \arg \min_{n \geq m^k} \left\{ \sum_{i=m^k}^n \Pr(M, n, i) - \sum_{i=m^k}^n p_i^k \right\}. \quad (2)$$

We update p_i^k as

$$p_i^k = \begin{cases} (1-w^k) p_i^{k-1}, & i \neq m^k \\ (1-w^k) p_{m^k}^{k-1} + w^k, & i = m^k \end{cases}, \quad (3)$$

where w^k ($0 < w^k < 1$) is the step size to update PMF. According to stochastic approximation theory [39], we can choose an appropriate step-size sequence to balance the convergence speed and smoothness.

Now we discuss how the value setting of M affects the estimation accuracy. As indicated by Eq. (1) and Eq. (2), larger M provides smaller estimation error. The tradeoff is that the overhead will increase with M . However, since T_{cs} is short, we can still take large M . In the 802.11 specification [1] for direct-sequence spread spectrum (DSSS), the clear channel assessment (CCA) must be less than $15 \mu\text{s}$, which means T_{cs} can be set on the time-scale of the default time-slot defined in 802.11 (a default time-slot in 802.11 DSSS equals $20 \mu\text{s}$). We assume that, even though the fading effect is counted, the busy-signal strength is still strong enough for detecting whether channel is busy.

D. Channel Negotiation

If the number of busy mini-slots is non-zero, all nodes will go into Phase II, the channel negotiation phase. In channel

negotiation phase, each node follows p -persistent algorithm or backoff algorithm to exchange ATIM messages. The time duration of channel negotiation phase, T_2 , is adjusted according to

$$T_2 = \min \left\{ T_2^{\max}, \beta \sum_{n=1}^{\hat{n}} T_s(n, p_t^*) \right\}, \quad (4)$$

where T_2^{\max} is a system parameter to limit T_2 , β is an adjusting parameter, \hat{n} is the number of active links estimated, and $T_s(n, p_t^*)$ is the minimal duration to complete an ATIM exchange given the number of participating node is n in p -persistent CSMA, to be explained in section IV-F.

Each winning link (node-pair) will select a channel for data exchange. The queue status, the number of radios on both sender and receiver, the channel quality and expected traffic load on each channel should be considered together to negotiate channel for transmit/receive data. We denote channel quality for link (i, j) at channel c as the weighted average signal-to-interference-plus-noise-ratio, $\overline{SINR}_{i,j,c}$. The achievable data rate R is a function of $\overline{SINR}_{i,j,c}$. The queue length for link (i, j) is denoted as $Q_i^j.\text{length}$. Other notations can be found in Table I. If channel c is selected, the requested time-allocation can be derived as

$$T_c^{req} = T_{over} \left\lceil \frac{Q_i^j.\text{length}}{L} \right\rceil + \frac{Q_i^j.\text{length}}{R(\overline{SINR}_{i,j,c})}. \quad (5)$$

Denote T_c^a as the available time-allocation in channel c and $T_c^a - T_c^{req}$ as the expected traffic load if channel c is selected for data exchange on link (i, j) . Smaller $T_c^a - T_c^{req}$ means heavier traffic load in the given channel. Clearly, choosing a channel with smaller traffic load will enable a link to transmit more data in current beacon interval and reduce time to complete data exchange, thus saving energy (we allow a radio to enter into doze state if it completes data exchange in current beacon-interval).

The channel and radio selection algorithm is shown in Fig. 4. The selection criterion is to choose the channel with smallest $T_c^a - T_c^{req}$ under the constraints that both sender and receiver have NICs which are available to run in the selected channel. Notice that a NIC can only run in one channel in each beacon-interval.

So far, we enforce that one active link (node-pair) can only use one channel even though both sender and receiver have multiple radios. We note it is beneficial to allow such an active link to use multiple channels if the traffic load of the given link is high while other links are not. However, it may degrade both throughput and energy efficiency if other links are also highly loaded because it introduces more channel contention and awake more radios. The other consideration is the out-of-order problem. Out-of-order problem arises in the link layer if the traffic distributed over multiple radios belong to the same end-to-end flow (each radio contends for channel independently).

E. Channel measurement

Rather than using channel probing technique to measure channel, which may consume significant bandwidth and en-

```

Procedure Initialization at node  $i$ 
/*at the beginning of each beacon-interval*/
{
1  for ( $1 \leq \kappa \leq K_i$ )
2     $NIC_i^{\kappa}.\text{channel} = \text{unassigned}$ ;
3  for ( $2 \leq c \leq C$ )
4     $T_c^a = T - T_1$ ;
5   $T_1^a = T - T_1 - T_2$ ;
6   $\kappa_i = K_i$ ;
7   $C_i^a = \{ \}$ ;
}

Procedure Channel and radio selection
/*for node-pair  $(i, j)$ */
{
1  if ( $\kappa_i > 0$  and  $\kappa_j > 0$ )
2  {
3     $c^* = \mathbf{argmax}_{1 \leq c \leq C} \{T_c^a - T_c^{req}\}$ ;
4     $NIC_i^{\kappa_i}.\text{channel} = c^*$ ;
5     $NIC_j^{\kappa_j}.\text{channel} = c^*$ ;
6     $\kappa_i = \kappa_i - 1$ ;
7     $\kappa_j = \kappa_j - 1$ ;
8     $C_i^a = C_i^a \cup \{c^*\}$ ;
9     $C_j^a = C_j^a \cup \{c^*\}$ ;
10 }
11 else if ( $\kappa_i > 0$  and  $\kappa_j \leq 0$ )
12 {
13    $c^* = \mathbf{argmax}_{c \in C_j^a} \{T_c^a - T_c^{req}\}$ ;
14    $NIC_i^{\kappa_i}.\text{channel} = c^*$ ;
15    $\kappa_i = \kappa_i - 1$ ;
16    $C_i^a = C_i^a \cup \{c^*\}$ ;
17 }
18 else if ( $\kappa_i \leq 0$  and  $\kappa_j > 0$ )
19 {
20    $c^* = \mathbf{argmax}_{c \in C_i^a} \{T_c^a - T_c^{req}\}$ ;
21    $NIC_j^{\kappa_j}.\text{channel} = c^*$ ;
22    $\kappa_j = \kappa_j - 1$ ;
23    $C_j^a = C_j^a \cup \{c^*\}$ ;
24 }
25 else if ( $\kappa_i \leq 0$  and  $\kappa_j \leq 0$ )
26 {
27    $c^* = \mathbf{argmax}_{c \in (C_i^a \cap C_j^a)} \{T_c^a - T_c^{req}\}$ ;
28 }
29  $T_c^a = T_c^a - T_c^{req}$ ;
}

```

Fig. 4. Channel and radio selection algorithm

ergy and require the coordination of each node-pair to keep in the same channel for channel measurement, we let a node estimate the SINR of the link originating from a neighbor by measuring the SINR of all the messages sent by the neighbor during the awake time of the node. In addition, we let the default channel for ATIM exchange keep hopping from one channel band to another in beacon-interval wise. Since each node follows the same hop-sequence, each node will keep awake in the same channel at the beginning of each beacon-interval. Denote the weighted average SINR and the newly observed SINR from node i to node j at channel

k as $\overline{SINR}_{i,j,k}$ and $SINR_{i,j,k}^{new}$, respectively. $\overline{SINR}_{i,j,k}$ is updated as below

$$\overline{SINR}_{i,j,c} = (1 - \alpha) \overline{SINR}_{i,j,c} + \alpha SINR_{i,j,c}^{new}, \quad (6)$$

where α is the forgetting factor.

F. p -persistent CSMA optimization

Now we discuss how to optimize medium-access parameter (e.g., the medium access probability of the p -persistent algorithm or the contention window size of the backoff algorithm) to minimize the average time to complete an ATIM/ACK exchange or complete RTS/CTS/DATA/ACK handshake.

The time of an idle slot T_{id} , the time of collision T_{col} , and the time spent for a successful contention T_{suc} are given as

$$\begin{cases} T_{id} = \sigma \\ T_{col}^{atim} = ATIM + DIFS \\ T_{suc}^{atim} = ATIM + SIFS + ACK_{atim} + DIFS \\ T_{col}^{data} = RTS + DIFS \\ T_{suc}^{data} = RTS + CTS + DATA + ACK_{data} \\ \quad \quad \quad + 3SIFS + DIFS \end{cases}, \quad (7)$$

where σ is a default time-slot size defined in 802.11.

In the p -persistent CSMA, the idle probability T_{id} , the success probability T_{suc} and the collision probability T_{col} can be represented as

$$\begin{cases} P_{id} = (1 - p)^n \\ P_{suc} = np(1 - p)^{n-1} \\ P_{col} = 1 - P_{id} - P_{suc} \end{cases}. \quad (8)$$

The average time for a successful transmission in the p -persistent CSMA is

$$T_s(n, p) = T_{suc} + \frac{P_{id}}{P_{suc}} T_{id} + \frac{P_{col}}{P_{suc}} T_{col}. \quad (9)$$

The optimal p in terms of minimal average service time can be derived as

$$p_t^* = \arg \min_{0 < p \leq 1} \{T_s(n, p)\}. \quad (10)$$

To save processing energy, optimal p can be achieved by looking up table instead of computing online. Now we discuss how to update n so that optimal p in terms of minimal average service time can be selected for channel access. We first discuss channel access procedure during channel negotiation phase, Phase II. We note there may be several links in a node attempting to advertise traffic. In our protocol, each active link emulates as a logical node to perform channel access procedure. As we mentioned earlier, each node can estimate the number of active links at the end of Phase I. In addition, each link needs only one successful ATIM exchange. So the remaining number of active links needing to exchange ATIM can be updated each time after a successful ATIM exchange is observed.

For channel access procedure for data exchange, the idea to update n is similar. Each node knows how many active links in a channel after channel negotiation phase, Phase II. If each data exchange (RTS/CTS/DATA/ACK) can piggyback queue status in the ACK, other nodes can also update the number of remaining active links.

V. PERFORMANCE MODELLING

In this section, we provide an analytical model to characterize how the throughput scales as the number of radios, the number of channels and the number of active links in the saturated case (each link always has packet for transmission).

To make analysis tractable, we make the following simplification. All channel have the same bandwidth, and have the same and constant channel quality. Each active link observes the same traffic load. Active links contend with each other (in contention graph) as long as they are in the same channel. For those nodes who have several active output links, each active link acts virtually as an independent link (with independent sender and receiver) to resolve channel contention (to exchange ATIM or data). All data packets have the same length with L bits. Data transmission is error(collision)-free after RTS/CTS exchange.

In addition, we do not consider Phase II for data exchange even in the channels other than the default channel. In other words, all data packets are exchanged on Phase III. Thus the throughput we derived in the following gives the conservative performance estimation we can achieve with our protocol.

A. Basics of p -persistent CSMA

We model p -persistent CSMA in one channel as a random sequence. Each stage in sequence represents one round of successful contention. $n^{(k)}$ and $p^{(k)}$ represent the number of participating nodes and medium access probability in stage k , respectively.

Denote $X(n^{(k)}, p^{(k)})$ (μs) as the MAC layer service time at stage k by p -persistent CSMA with $n^{(k)}$ nodes and medium-access probability $p^{(k)}$. $X(n^{(k)}, p^{(k)})$ is a random variable. $\sum_{k=1}^i X(n^{(k)}, p^{(k)})$ is the total service time from stage 1 to stage i (including stage 1 and stage i). Let $q_j^{(k)}$ be the probability that $X(n^{(k)}, p^{(k)})$ equals j (μs , in the discrete manner). Denote $q_j^{(1 \Rightarrow i)}$ as the probability that $\sum_{k=1}^i X(n^{(k)}, p^{(k)})$ equals j (μs , in the discrete manner). Both $q_j^{(k)}$ and $q_j^{(1 \Rightarrow i)}$ are derived in Section V-C.

$X(n^{(k)}, p^{(k)})$ depends only on $(n^{(k)}, p^{(k)})$. $p^{(k)}$ is set based on $n^{(k)}$. If $n^{(k)}$ is determined once stage index k is determined, X is independent random process, which implies that $X(n^{(i)}, p^{(i)})$ and $X(n^{(j)}, p^{(j)})$ are independent random variables. Denote $n_{atim}^{(k)}$ as the number of intending advertising links at stage k in channel negotiation phase, Phase II. $n_{atim}^{(k)}$ is shown as below

$$n_{atim}^{(k)} = n - k + 1, \quad 1 \leq k \leq i_{max}^{atim}. \quad (11)$$

Denote $n_{c,data}^{(k)}$ as the number of links remaining active at stage k in channel c . In the saturated case, $n_{c,data}^{(k)}$ is a constant. However, in the non-saturated case, $n_{c,data}^{(k)}$ reduces by one once after an active link completes the data transmission. The initial number of active links assigned to each channel (negotiated in Phase II) depends on the number of channels, the number of radios in each node and the resource constraints, as specified in Fig. 4. For example, in the saturated case, if

the total number of active incoming links and active output links in each node is not larger than the number of radios in that node, the initial number of active links $n_{c,data}^{(1)}$ in channel c can be represented as

$$n_{c,data}^{(1)} = \begin{cases} \lfloor (i-1)/C \rfloor + 1, & 1 \leq c \leq i - \lfloor (i-1)/C \rfloor C \\ \lfloor i/C \rfloor, & \text{Otherwise} \end{cases}, \quad (12)$$

where i_{atim} is the number of active links having successfully exchange ATIM via contention in Phase II, and C is the total number of channels. In another saturated case, if all links winning in Phase II are the input links and/or output links of the same node, $n_{c,data}^{(1)}$ is represented as

$$n_{c,data}^{(1)} = \begin{cases} 0, & c > K \\ \lfloor (i-1)/K \rfloor + 1, & 1 \leq c \leq i - \lfloor (i-1)/K \rfloor K \\ \lfloor i/K \rfloor, & \text{Otherwise} \end{cases}, \quad (13)$$

where K is the number of radios in the bottleneck node (We assume K is not larger than C).

B. Saturated Throughput

Denote $P_i^{atim}(\vec{n}_{atim}, \vec{p}_{atim}, T_2)$ (abbreviated as P_i^{atim}) as the probability that i active links successfully exchange ATIM via contention in channel negotiation Phase II, given the intended advertising link number sequence \vec{n}_{atim} , the medium-access probability sequence \vec{p}_{atim} and Phase II duration T_2 . Both \vec{n}_{atim} and \vec{p}_{atim} are $1 \times i_{max}^{atim}$ vectors. i_{max}^{atim} is the maximal possible number of active links which can successfully exchange ATIM.

$$i_{max}^{atim} = \min \left\{ \left\lfloor \frac{T_2 + DIFS}{T_{suc}^{atim}} \right\rfloor, n \right\}, \quad (14)$$

where n is the initial total number of intended advertising links.

Let $P_i^{c,data}(\vec{n}_{c,data}, \vec{p}_{c,data}, T_3)$ (abbreviated as $P_i^{c,data}$) be the probability that i data packets are successfully exchanged on channel c in Phase III, given the number sequence $\vec{n}_{c,data}$, the medium-access probability sequence $\vec{p}_{c,data}$ and Phase III duration T_3 . Both $\vec{n}_{c,data}$ and $\vec{p}_{c,data}$ are $1 \times i_{max}^{data}$ vectors. i_{max}^{data} is the maximal possible number of data transmission which can be completed during Phase III.

$$i_{max}^{data} = \left\lfloor \frac{T_3 + DIFS}{T_{suc}^{data}} \right\rfloor \quad (15)$$

To derive saturated throughput, we need to calculate $P_i^{atim}(\vec{n}_{atim}, \vec{p}_{atim}, T_2)$ and $P_i^{c,data}(\vec{n}_{c,data}, \vec{p}_{c,data}, T_3)$. A general formulation of $P_i(\vec{n}, \vec{p}, T)$ is shown as

$$P_i(\vec{n}, \vec{p}, T) = \begin{cases} \Pr \left(\sum_{k=1}^{i_{max}} X(n^{(k)}, p^{(k)}) \leq T \right), & i = i_{max} \\ \Pr \left(\sum_{k=1}^i X(n^{(k)}, p^{(k)}) \leq T \right) \\ - \sum_{j=i+1}^{i_{max}} P_j(\vec{n}, \vec{p}, T), & 0 < i < i_{max} \end{cases}. \quad (16)$$

Note that $X(n^{(k)}, p^{(k)})$ ($1 < k < i_{\max}$) in Phase II and Phase III (for saturated case) are independent random variables. So, $\Pr\left(\sum_{k=1}^i X(n^{(k)}, p^{(k)}) \leq T\right)$ can be calculated as

$$\Pr\left(\sum_{k=1}^i X(n^{(k)}, p^{(k)}) \leq T\right) = \sum_{j=1}^T q_j^{(1 \Rightarrow i)}, \quad (17)$$

where $q_j^{(1 \Rightarrow i)}$ is derived in Eq. (21).

Finally, we obtain the throughput as

$$S = \frac{L}{T_{\text{int}}} \left\{ \sum_i \left\{ \frac{P_i^{\text{atim}} (\vec{n}_{\text{atim}}, \vec{p}_{\text{atim}}, T_2) \times \sum_{c=1}^C \sum_j j P_j^{c, \text{data}} (\vec{n}_{c, \text{data}}, \vec{p}_{c, \text{data}}, T_3)} \right\} \right\}, \quad (18)$$

where T_{int} is the length of beacon-interval, which equals $T_1 + T_2 + T_3$ (we do not consider the time for beacon synchronization).

C. MAC service time distribution of p -persistent CSMA

We use the probability generation function (PGF) approach [38] to derive the probability mass function (PMF) of MAC service time distribution. We first focus on the MAC service time distribution of one particular stage. Then we discuss how to derive the MAC service time distribution of multiple successive stages (one stage represents one round of successful contention) if all stages are independent.

For stage k , the probability generation function of a probability mass function (PMF) $q_j^{(k)}$ (where $\sum_j q_j^{(k)} = 1$) is defined by

$$H_t^{(k)}(z) = \sum_j q_j^{(k)} z^j. \quad (19)$$

It is clear that $H_t^{(k)}(z)$ is the z -transform of the discrete sequence $q_j^{(k)}$. Hence, once we know $H_t^{(k)}(z)$, we can calculate the inverse z -transform of $H_t^{(k)}(z)$ to obtain the PMF $q_j^{(k)}$.

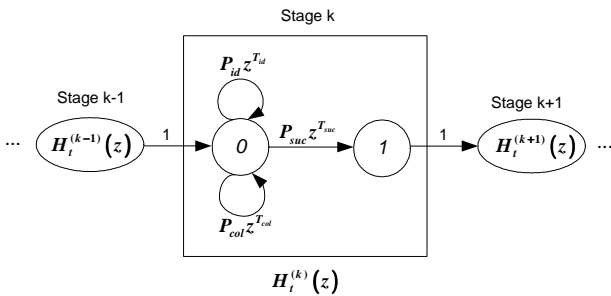

Fig. 5. The signal flow graph for obtaining $H_t(z)$

In deriving $H_t^{(k)}(z)$, we use the signal-flow graph shown in Fig. 5 to portray the transitions of the system state from the end of the last stage $k-1$ to the beginning of next stage $k+1$, and the respective branch gains (characterized by the probability of transitions and the associated delay) within current stage k . In Fig. 5, the probability of the transition from the end of last stage $k-1$ to the state 0 in current stage k is one and the delay is zero, and hence the corresponding branch gain is

one; similarly, the branch gain from state 1 in current stage k to the beginning of next stage $k+1$ is also one. There are two self loops for state 0 in current stage: one loop corresponds to the channel being idle (no transmission), and the other loop corresponds to an occurrence of collision. The transition from state 0 to state 1 indicates a successful transmission. T_{id} , T_{col} , T_{suc} , P_{id} , P_{col} , P_{suc} are indicated by Eq. (7) and Eq. (8).

Note that the time T_{id} , T_{col} , and T_{suc} are integers and have units of μs . Based on the signal-flow graph in Fig. 5, we can use the general gain formula (Mason's rule) [37] to obtain $H_t^{(k)}(z)$ as below

$$H_t^{(k)}(z) = \frac{P_{suc} z^{T_{suc}}}{1 - P_{id} z^{T_{id}} - P_{col} z^{T_{col}}}. \quad (20)$$

Then, we can obtain $q_j^{(k)}$ using the inverse z -transform. We refer the above approach to achieve $H_t^{(k)}(z)$ as the generalized state transition approach, which can also be found in [36] [38].

We notice that the first derivative of $H_t(z)$ at $z = 1$ equals the average MAC service time as shown in Eq. (9), which confirms the validity of Eq. (20).

Now we discuss how to derive the total MAC service time distribution of multiple successive stages. From stage 1 to stage i , the probability generation function of a probability mass function (PMF) $q_j^{(1 \Rightarrow i)}$ (where $\sum_j q_j^{(1 \Rightarrow i)} = 1$) is defined by

$$H_t^{(1 \Rightarrow i)}(z) = \sum_j q_j^{(1 \Rightarrow i)} z^j. \quad (21)$$

It is clear that $H_t^{(1 \Rightarrow i)}(z)$ is the z -transform of the discrete sequence $q_j^{(1 \Rightarrow i)}$. If one stage is independent from another, based on the general gain formula (Mason's rule) [37], $H_t^{(1 \Rightarrow i)}(z)$ can be derived as

$$H_t^{(1 \Rightarrow i)}(z) = \prod_{k=1}^i H_t^{(k)}(z). \quad (22)$$

Then, we can obtain $q_j^{(1 \Rightarrow i)}$ using the inverse z -transform.

VI. RESULTS AND DISCUSSIONS

We compare our protocol with the enhancement of IEEE 802.11 PSM (indicated as 80211-PSM+ in our figures), which uses the same timing structure and channel access mechanism (binary exponential backoff based CSMA/CA) as IEEE 802.11 PSM but can balance traffic over multiple channels.

We set parameters for analysis and simulation as follows. The transmission rate for both control messages and data packets is 2Mbps. The data packet length is fixed at 512 bytes. The beacon-interval is 100ms. T_{2max} is 20ms. The ATIM window for 80211-PSM+ is fixed at 20ms. w^k is set to $1/k$. T_{cs} is 40 μs . M is 25. β is set to 1.2. The simulation results provided are the results under the stable state. We vary the number of active links from 2 to 20, traffic load from 1 packet/sec/link to 10 packets/sec/link, the number of channels from 1 to 5. For brevity, we only consider the scenario under which the total number of active incoming links and active outgoing links in each node is not larger than the number of

radios in that node. The power consumed for a radio in the transmit state, the receive state, the idle state and the doze state are set to 1.8 W, 1.3 W, 1.0 W and 0.05 W, respectively. A link in the transmit state means the radio in the head of the link is in the transmit state and the radio in the tail of the link is in the receive state. A link in the receive state, in the idle state, and in the doze state means both the radio in the head of the link and the radio in the tail of the link are in the receive state, in the idle state, and in the doze state, respectively. So P_{tx} , P_{rx} , P_{idle} and P_{doze} , which denote the power consumption of a link in each state, equal 3.1 W, 2.6 W and 2.0 W, and 0.1 W, respectively. Other parameters are set to the default values in 802.11b ns2.

We compare simulation results with analytical results so that the accuracy of analytical model can be validated.

Fig. 6 and Fig. 7 show the throughput and energy efficiency in the saturated case, respectively. Note the number of winning active links within the ATIM window in our proposed protocol is almost the same as that in 80211-PSM+; so it is a fair comparison for the saturated throughput and energy efficiency. Both the throughput and the energy efficiency of our proposed protocol are higher than that under 80211-PSM+, especially when the number of active links is small. As the number of active links increases, the throughput and energy efficiency gain of our proposed protocol over 80211-PSM+ shrinks. This is mainly due to the fact that ATIM window in 80211-PSM+ is fixed. But the ATIM window in our proposed protocol can be adaptive to the number of intended advertising links. In 80211-PSM+, the less the number of intended advertising links, the more time and energy are wasted for no use in ATIM window. We also notice that, given the number of active links, both throughput and energy efficiency are doubled as the number of channel increases from 1 to 2. This is reasonable since the number of contending links in each channel is reduced to half as the number of channel increases from 1 to 2. We do not provide results for the cases when the number of channels is 3, 4 and 5, respectively, due to the space limit. But we have done extensive simulations, which show that both throughput and energy consumption have the similar scaling behavior when the number of channels increases. We also observe that the proposed analytical model is quite accurate in characterizing the saturated throughput.

Fig. 8 and Fig. 9 show the energy efficiency and delay performance in the non-saturated case, respectively. Note the total throughput in our proposed protocol is almost the same as that in 80211-PSM+; so it is a fair comparison for non-saturated energy efficiency and delay performance. Our proposed protocol significantly improves energy efficiency and delay performance as compared to 80211-PSM+, especially when traffic load is low. The energy efficiency gain is due to three factors. First, our protocol adapts ATIM window size to be just enough for exchanging all ATIMs so that energy can be saved; otherwise, it wastes energy to stay in the idle state after all links complete ATIM exchanges. Second, our protocol allows each link completing data exchange to enter the doze state while 80211-PSM+ requires each link with exchanged

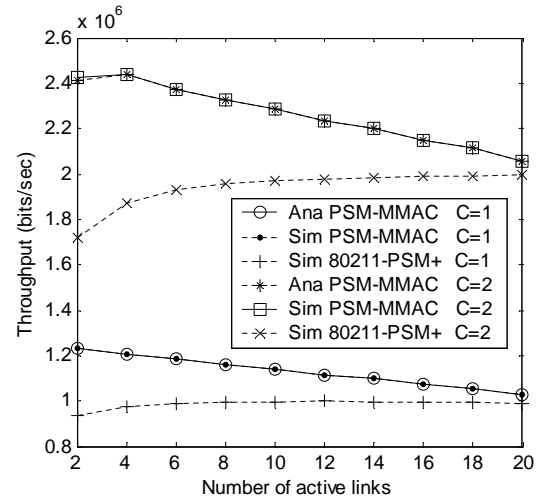

Fig. 6. Throughput in saturated case.

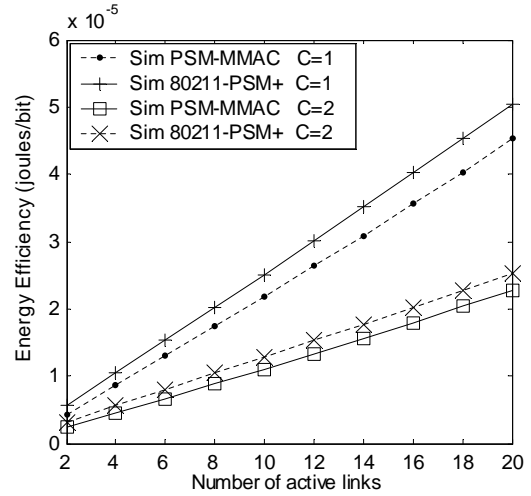

Fig. 7. Energy efficiency in saturated case

ATIMs to stay in the awake state during the whole beacon-interval even after it has completed data exchange. Third, our protocol optimizes the medium access probability for both ATIM exchanges and data exchanges so that energy wasted for idleness or collisions is reduced. We notice that the energy efficiency for 80211-PSM+ improves significantly when traffic load increases and the energy efficiency for our proposed protocol is relatively stable. This is reasonable. We can divide the energy consumption per payload bit into two parts; one is consumed in ATIM window and another is consumed in data exchange. For 80211-PSM+, under the low traffic load case, energy efficiency of both parts improves when the traffic load increases (the throughput increases as the traffic load increases under the low traffic load case) since less energy per payload bit is wasted for being idle in ATIM window (after ATIM exchanges) and in data exchange phase (after data exchanges). For our proposed protocol, the energy efficiency maintains

relatively stable since the energy consumption per payload bit for ATIM exchange reduces as the throughput increases (with the increase of traffic load) even though the energy consumption per payload bit for data exchange increases as the traffic load increases (since more active links keep awake for channel contention). The improvement of delay performance under our protocol is mainly due to the two aforementioned factors. First, our protocol adapts ATIM window size to be just enough for exchanging all ATIMs. Second, our protocol optimizes the medium access probability for both ATIM exchanges and data exchanges.

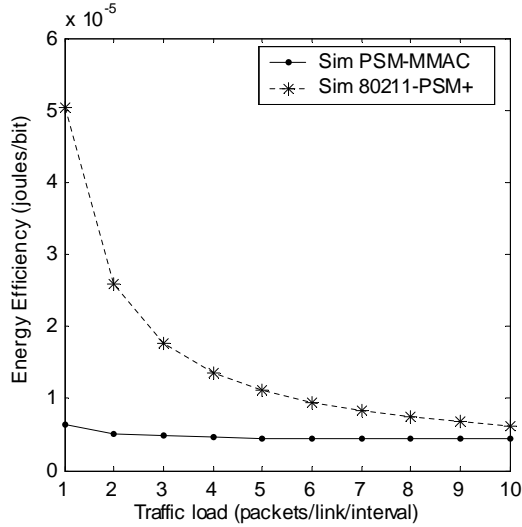

Fig. 8. Energy efficiency in non-saturated case. The number of active links is 10. The number of channels is 5.

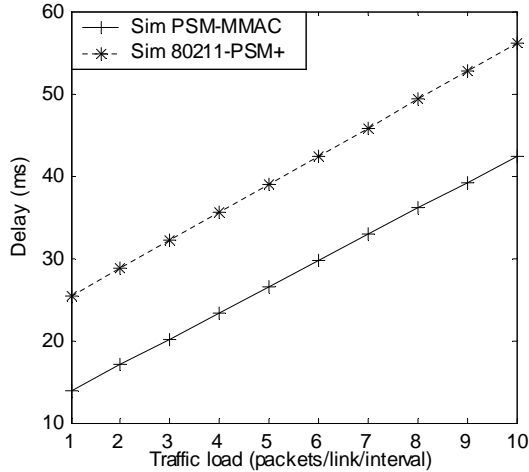

Fig. 9. Delay in non-saturated case. The number of active links is 10. The number of channels is 5.

Fig. 10 and Fig. 11 provide more results on throughput and energy efficiency as a function of traffic load and the number of channels. The throughput increases almost linearly as the

traffic load increases until the system becomes highly loaded. More channels give larger non-saturated throughput region. The energy consumption per payload bit of 80211-PSM+ decreases as the traffic load increases until the throughput becomes saturated. The energy efficiency of our proposed protocol maintains relatively stable but varies slightly with traffic load. The reason of this has been given in the previous paragraph.

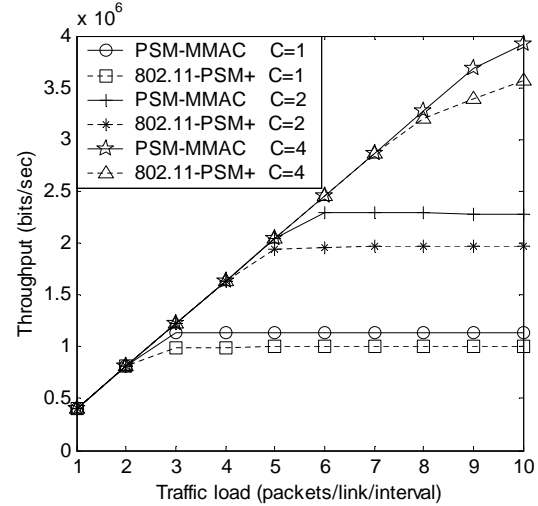

Fig. 10. Throughput vs. traffic load and number of channels. The number of active links is 10.

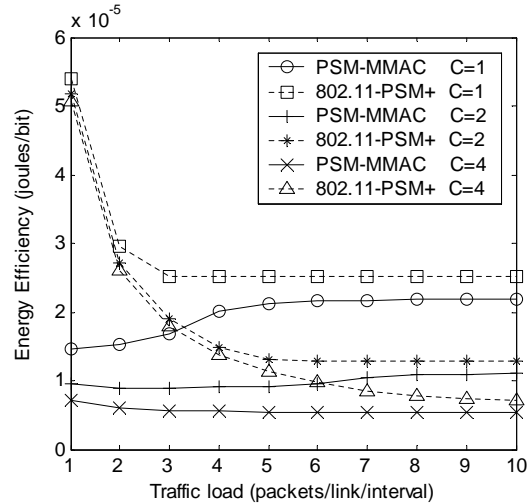

Fig. 11. Energy vs. traffic load and number of channels. The number of active links is 10.

VII. CONCLUSIONS

In this paper, we studied the joint design of multi-channel medium-access and power management for heterogeneous multi-radio wireless LANs. This design problem is particularly challenging due to the conflicting nature of the multi-radio capability of a node. To address this problem, we proposed

a power-saving multi-channel MAC protocol (PSM-MMAC), which is capable of reducing the collision probability and the waiting time in the ‘awake’ state of a node, resulting in improved throughput, delay performance, and energy efficiency. One nice feature of PSM-MMAC is that it can cope with a heterogeneous multi-radio system, in which each node may have different number of radios. The implementation of PSM-MMAC requires minimal modification of 802.11 hardware. Another contribution of this paper is an analytical model that characterizes the throughput performance. Simulation results validated the accuracy of our analytical model and showed that our proposed protocol can significantly improve throughput and energy efficiency and reduce delay in fair comparison with IEEE 802.11 PSM.

REFERENCES

- [1] Part 11: Wireless LAN Medium Access Control (MAC) and Physical Layer (PHY) Specifications. *ANSI/IEEE Std 802.11*, 1999 Edition.
- [2] T. S. Rappaport. *Wireless Communications: Principles and Practice*. Prentice Hall, 2002.
- [3] F. Herzel, G. Fischer, and H. Gustat. An Integrated CMOS RF Synthesizer for 802.11a Wireless LAN. *IEEE Journal of Solid-state Circuits*, Vol. 38, No. 10, October 2003.
- [4] P. Bahl, A. Adya, J. Padhye, and A. Wolman. Reconsidering Wireless Systems with Multiple Radios. *SIGCOMM Computer Communication Review*, July 2004.
- [5] P. Kyasanur and N. Vaidya. Capacity of Multi-Channel Wireless Networks: Impact of Number of Channels and Interfaces. To appear in *Proc. of Mobicom*, 2005.
- [6] A. Nasipuri, J. Zhuang and S. R. Das. A Multichannel CSMA MAC Protocol for Multihop Wireless Networks. In *Proc. of IEEE WCNC*, September 1999.
- [7] A. Nasipuri and S. R. Das. Multichannel CSMA with Signal Power-based Channel Selection for Multihop Wireless Networks. In *Proc. of IEEE VTC*, September 2000.
- [8] J. Zhang and D. Zheng. Ad Hoc Networking Over Fading Channels: Multi-Channel Diversity, Signaling, and Opportunistic Medium Access Control. 41th Allerton Conference on Communications, Control, and Computing, Oct. 2003.
- [9] S.-L. Wu, C.-Y. Lin, Y.-C. Tseng, and J.-P. Sheu. A New Multi-Channel MAC Protocol with On-Demand Channel Assignment for Multi-Hop Mobile Ad Hoc Networks. In *Intl Symposium on Parallel Architectures, Algorithms and Networks (IS-PAN)*, 2000.
- [10] N. Jain and S. Das. A Multichannel CSMA MAC Protocol with Receiver-Based Channel Selection for Multihop Wireless Networks. In *Proc. of IEEE ICCCN*, October 2001.
- [11] W. Hung, K. Law, and A. Leon-Garcia. A Dynamic Multi-Channel MAC for Ad Hoc LAN. In *21st Biennial Symposium on Communications*, Kingston, Canada, June 2002, pp. 31-35.
- [12] A. Tzamaloukas and J.J. Garcia-Luna-Aceves. A Receiver-Initiated Collision-Avoidance Protocol for Multi-Channel Networks. In *Proc. of Infocom*, 2001.
- [13] P. Bahl, R. Chandra, and J. Dunagan. SSCH: Slotted Seeded Channel Hopping for Capacity Improvement in IEEE 802.11 Ad-Hoc Wireless Networks. In *Proc. of Mobicom*, Philadelphia, Pennsylvania, September, 2004.
- [14] J. So and N. Vaidya. Multi-Channel MAC for Ad Hoc Networks: Handling Multi-Channel Hidden Terminals Using A Single Transceiver. In *Proc. of Mobihoc*, Roppongi, Japan, 2004.
- [15] V. Kanodia, A. Sabharwal, and E. Knightly. MOAR: A Multi-channel Opportunistic Auto-rate Media Access Protocol for Ad Hoc Networks. In *Proc. of the International Conference on Broadband Networks (Broadnets)*, San Jose, CA, October 2004.
- [16] X. Tian, Y. Fang and T. Ideguchi. MATS: Multichannel Time-Spread Scheduling in mobile ad hoc networks. Accepted for publication in *IEEE Transactions on Wireless Communications*.
- [17] A. Adya, P. Bahl, J. Padhye, A. Wolman, and L. Zhou. A Multi-Radio Unification Protocol for IEEE 802.11 Wireless Networks. In *Proc. of the International Conference on Broadband Networks (Broadnets)*, San Jose, CA, October 2004.
- [18] P. Kyasanur and N. Vaidya. Routing and Interface Assignment in Multi-Channel Multi-Interface Wireless Networks. In *Proc. of IEEE WCNC*, 2005.
- [19] A. Raniwala and T. Chiueh. Architecture and Algorithms for an IEEE 802.11-Based Multi-Channel Wireless Mesh Network. In *Proc. of INFOCOM*, 2005.
- [20] S.-L. Wu, Y.-C. Tseng, C.-Y. Lin, and J.-P. Sheu. A Multi-Channel MAC Protocol with Power Control for Multi-Hop Mobile Ad Hoc Networks. *The Computer Journal*, Vol. 45, No. 1, 2002, pp. 101-110.
- [21] H. Woesner, J. Ebert, M. Schlager and A. Wolisz. Power-saving Mechanisms in Emerging Standards for Wireless LANs: The MAC Level Perspective. *IEEE Personal Communications*, June 1998.
- [22] L. Feeney, M. Nilsson. Investigating the Energy Consumption of a Wireless Network Interface in an Ad Hoc Networking Environment. In *Proc. of INFOCOM*, 2001, pp. 85C96.
- [23] J. Ebert and A. Wolisz. Combined Tuning of RF Power and Medium Access Control for WLANs. *Mobile Networks & Applications*, vol. 5, no. 6, pp. 417C426, Sep. 2001.
- [24] D. Qiao, S. Choi, A. Jain and K. G. Shin. MiSer: An Optimal Low-Energy Transmission Strategy for IEEE 802.11a/h. In *Proc. ACM MobiCom*, San Diego, CA, Sep. 2003, pp. 161C175.
- [25] A. Muqattash and M. Krunz. POWMAC: A Single-Channel Power-Control Protocol for Throughput Enhancement in Wireless Ad Hoc Networks. *IEEE Journal on Selected Areas in Communications (JSAC)*, Vol. 23, Issue 5, pp. 1067-1084, May 2005.
- [26] B. Chen, K. Jamieson, H. Balakrishnan, and R. Morris. Span: An Energy-Efficient Coordination Algorithm for Topology Maintenance in Ad Hoc Wireless Networks. In *Proc. ACM MobiCom*, Rome, Italy, 2001, pp. 85C96.
- [27] E. Jung and N. Vaidya. An Energy Efficient MAC Protocol for Wireless LANs. In *Proc. of INFOCOM*, 2002.
- [28] Y. Tseng, C. Hsu and T. Hsieh. Power-Saving Protocols for IEEE 802.11-Based Multi-Hop Ad Hoc Networks. In *Proc. of INFOCOM*, 2002.
- [29] J.-M. Choi, Y.-B. Ko, and J.-H. Kim. Enhanced Power Saving Scheme for IEEE 802.11 DCF based Wireless Networks. In *IFIP Personal Wireless Communication (PWC) 2003*, September 2003.
- [30] R. Zheng and R. Kravets. On-demand Power Management for Ad Hoc Networks. In *IEEE INFOCOM 2003*, April 2003.
- [31] M. Miller and N. Vaidya. Improving Power Save Protocols Using Carrier Sensing and Busy-Tones for Dynamic Advertisement Window, Technical Report, December 2004.
- [32] R. Bruno, M. Conti and E. Gregori. Optimization of Efficiency and Energy Consumption in *p*-Persistent CSMA-Based Wireless LANs. *IEEE Transactions on Mobile Computing*, Vol. 1, No. 1, Jan-Mar 2002.
- [33] D. Qiao and K. G. Shin. Smart Power-Saving Mode for IEEE 802.11 Wireless LANs. In *Proc. of INFOCOM*, 2005.
- [34] Y. Kwon, Y. Fang and H. Latchman. A Novel Medium Access Control Protocol with Fast Collision Resolution for Wireless LANs. In *Proc. of INFOCOM*, San Francisco, California, March/April 2003.
- [35] B. Sadeghi, V. Kanodia, A. Sabharwal and E. Knightly. Opportunistic Medium Access for Multirate Ad Hoc Networks. In *Proc. of MOBICOM*, 2002.
- [36] D. W. Choi. Frame Alignment in a Digital Carrier System - A Tutorial. *IEEE Communications Magazine*, 1990, 28(2):47-54.
- [37] N. S. Nise. *Control Systems Engineering*. 2nd edition, Addison-Wesley Publishing Company, 1995.
- [38] H. Zhai, Y. Kwon, and Y. Fang. Performance Analysis of IEEE 802.11 MAC Protocol in Wireless LAN. *Wiley Journal of Wireless Communications and Mobile Computing (WCMC)*, 2004;4:917-931.
- [39] H. Kushner and G. Yin. *Stochastic Approximation and Recursive Algorithms and Applications*. Springer; 2 edition (July 17, 2003). ISBN: 0387008942.